

Cryogen-free cryostat with sample changer for fast automatic data collection

Melanie Resag, Heinrich Kolb, Jürgen Peters

MLZ is a cooperation between:

Thermal decoupling of the sample desk

Enhancement: Longer thermal decoupling

Problems faced: Leaks due to thermal stress and/or pressure load

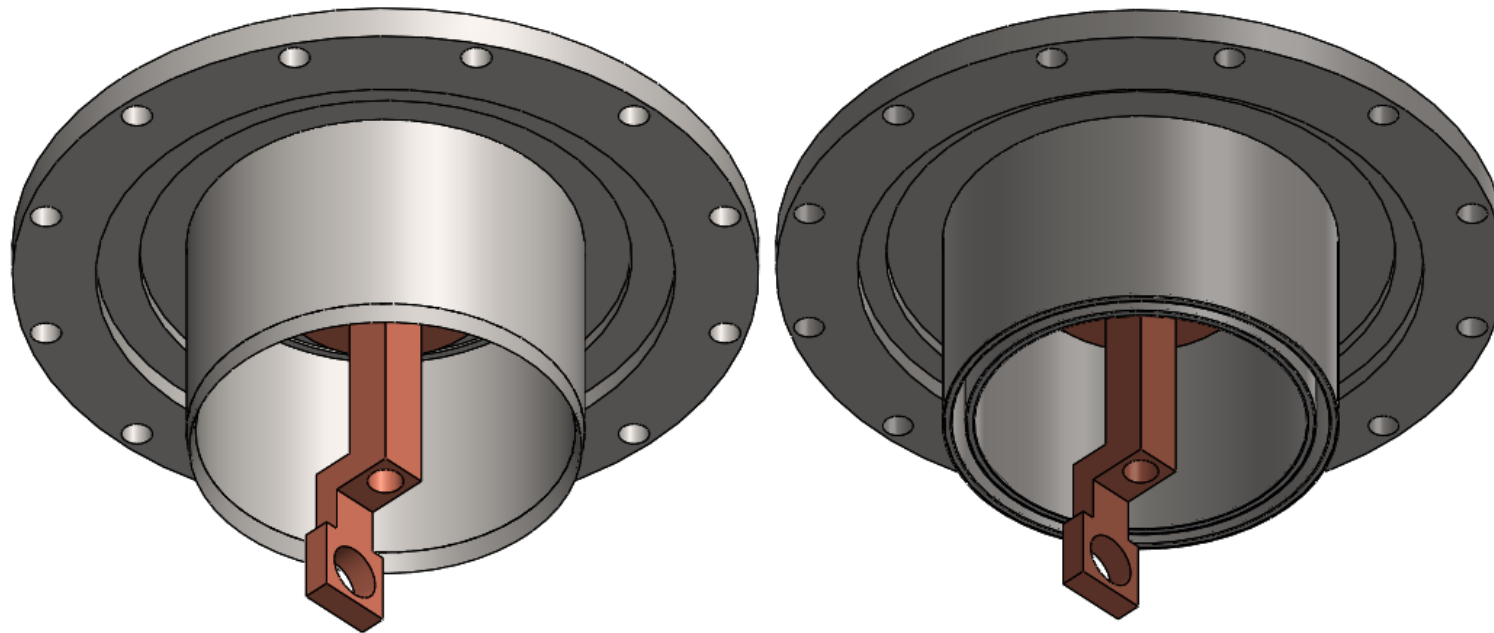

Thermal decoupling: Our design

Single pair of cylinders

Bent endings for weld connection

⇒ Rejected by manufacturing company, design too complicated

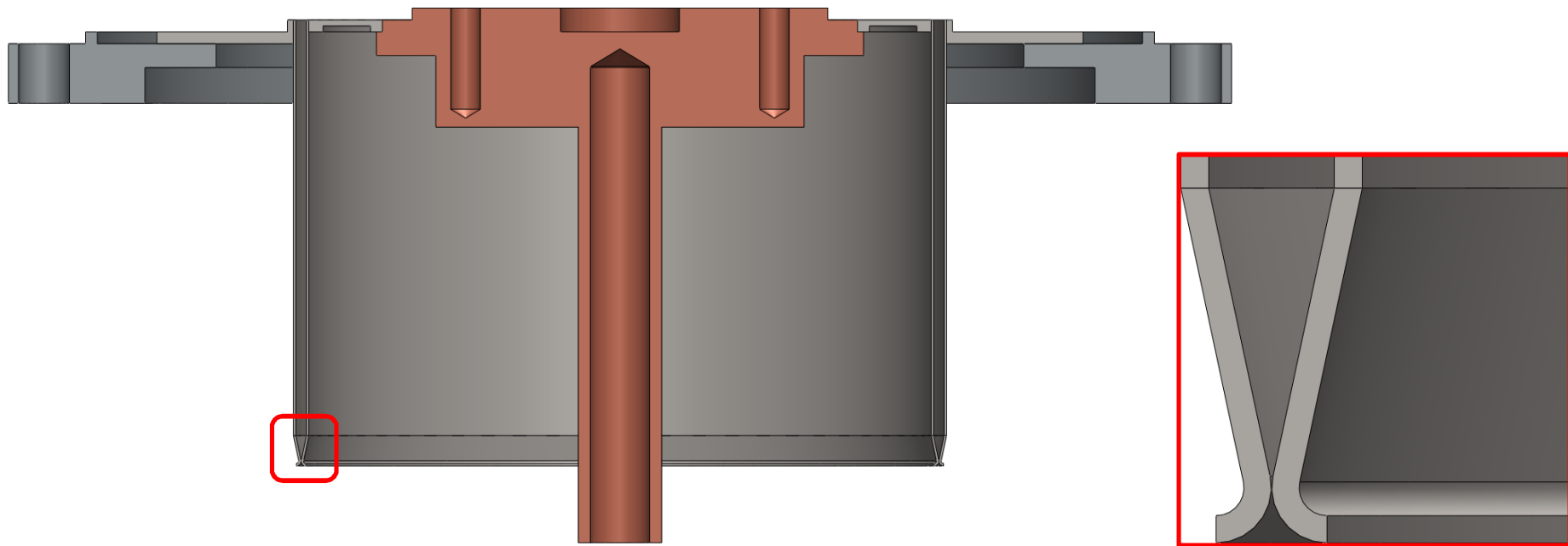

Thermal decoupling: Enhanced design 1

First single pair, later double pair of cylinders (due to thermal input)

Ring welded between cylinders

⇒ Connection does not withstand thermal stresses and/or alternating pressure loads

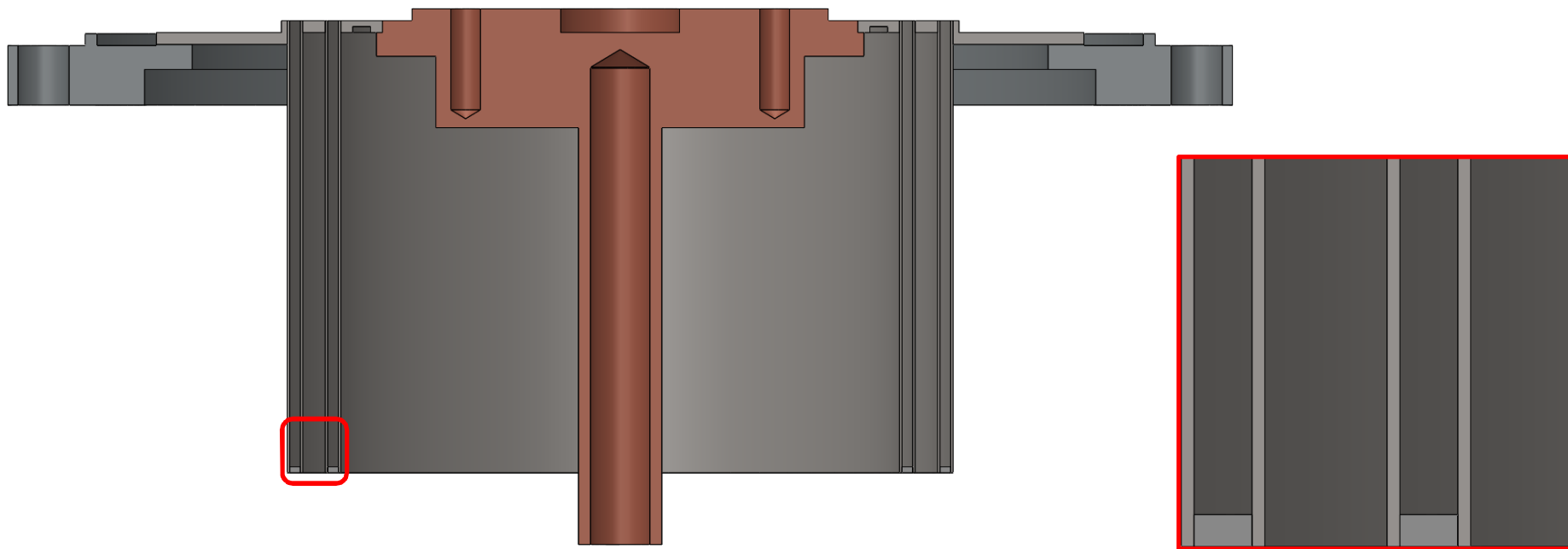

Thermal decoupling: Enhanced design 2

Double pair of cylinders with solder seam

Each cylinder turned separately

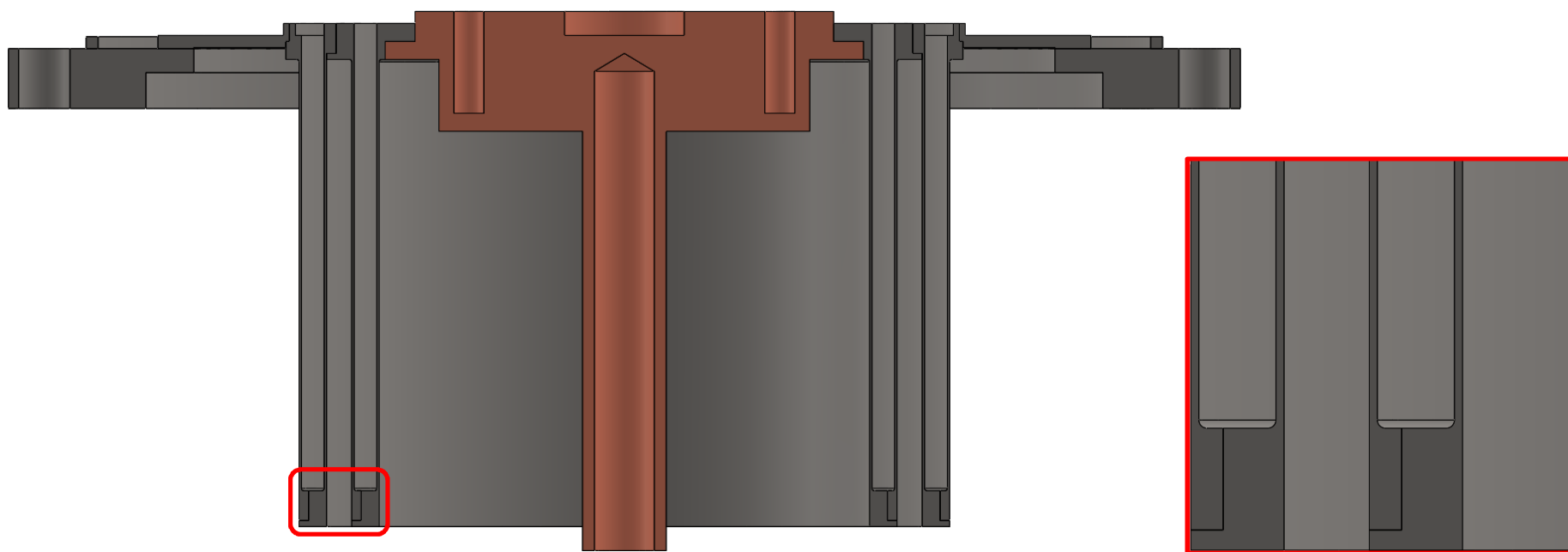

Thermal decoupling: Enhanced design 2

Double pair of cylinders with solder seam

Each cylinder turned separately

Solder connection between the cylinders for elasticity

Welding connection between sample desk and cylinders

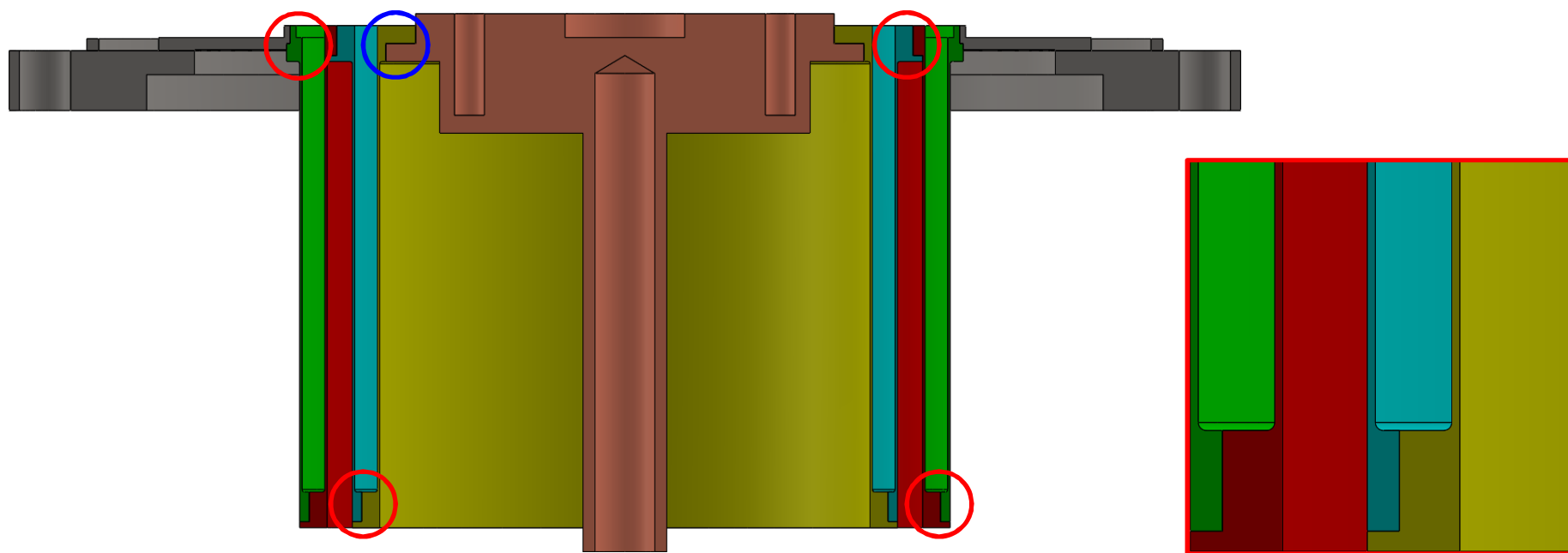

Thermal decoupling: Enhanced design 2

Huge problems to get the solder connections sealed properly

- ⇒ solder ring between cylinders
- ⇒ electron beam heating

Leakages along inner cylinder surface

- ⇒ cutting the outer surfaces
- ⇒ soldering the inner cylinder
- ⇒ welding the outer surface

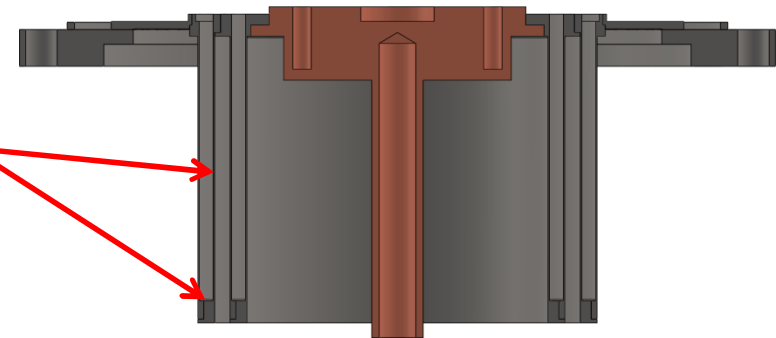

- ⇒ Solder connections withstand thermal and pressure loads so far
- ⇒ Simpler design for future sample desks:
 - four standard cylinders
 - thicker rings for brazing fit

Thank you for your attention!



This research project has been supported by
the European Commission under the 7th Framework Program
through the 'Research Infrastructures' action of the 'Capacities' Program,
NMI3-II Grant number 283883

MLZ is a cooperation between:

